

**NOTE**

Plans produced for the purpose stated below only.  
 All dimensions to be checked on site  
 This drawing is the copyright of HH CAD Plans ©

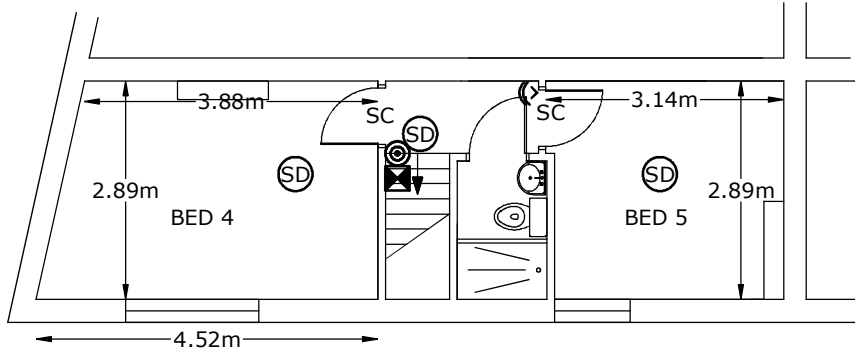

SECOND FLOOR

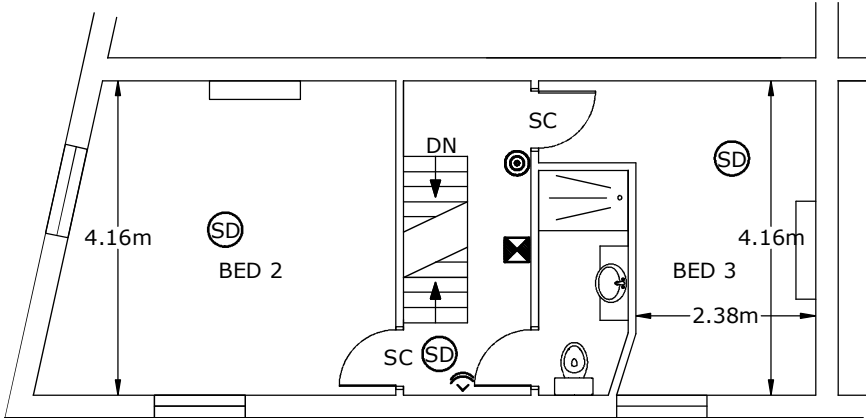

FIRST FLOOR

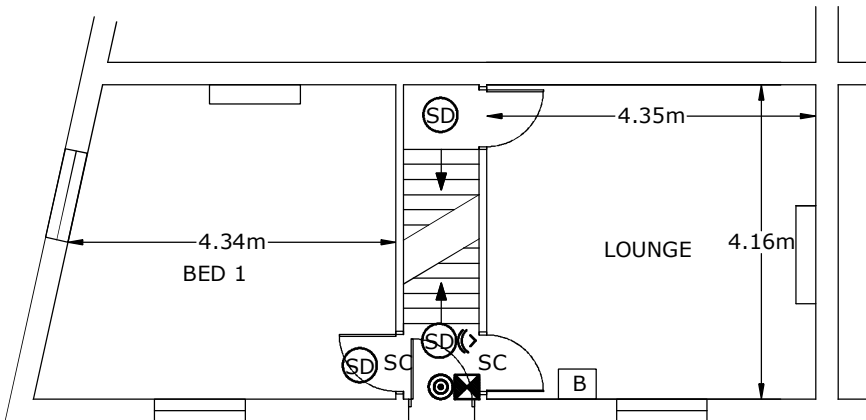

GROUND FLOOR

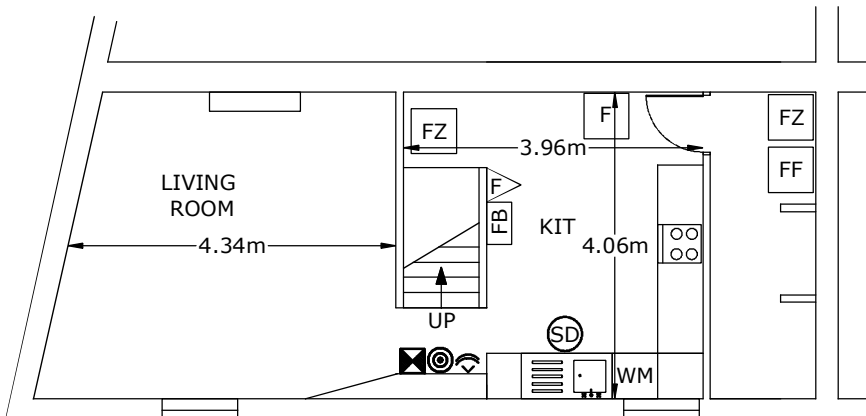

LOWER GROUND FLOOR

- LR Compliant Plan
- Marketing Plan
- Measured Survey
- Space Planning
- CAD Re-draw from hard-copy
- HMO Floor Plan ✓

- SC SELF CLOSING DEVICE
- ⊙ SMOKE DETECTOR
- ⊙ MANUAL CALL POINT
- ⊠ EMERGENCY LIGHT
- ⤷ FIRE ALARM SANDER
- ⊠ FIRE EXTINGUISHER
- ⊠ FIRE BLANKET
- ⊠ FRIDGE
- ⊠ FREEZER
- ⊠ FRIDGE-FREEZER
- ⊠ WASHING MACHINE
- ⊠ BOILER



www.hhcadplans.co.uk  
 hhcadplans@gmail.com  
 07768 310686

Project : 1 THORNVILLE MOUNT  
 LEEDS  
 LS1 1JX

Drawing Title : HMO FLOOR PLANS

Project Number:  
 11029

Drawing Number:  
 50055

Plotted Scale: 1/100

Date: 13 JAN 2014  
 Drawn by:  
 HMH

Client: S & B Properties  
 6-8 York Place  
 Leeds  
 LS1 2DS